

EFFECT OF IONIC CROSSLINKING ON DENSITY OF HYDROGEL CHITOSAN MEMBRANES

**Magdalena Gierszewska-Drużyńska,
Jadwiga Ostrowska-Czubenko, Anita Kwiatkowska**

*Chair of Physical Chemistry and Physicochemistry of Polymers,
Faculty of Chemistry
Nicolaus Copernicus University,
ul. Gagarina 7, 87-100 Toruń, Poland
E-mail: mgd@chem.umk.pl*

Abstract

Ionically crosslinked chitosan membranes were prepared and their density was determined using modified pycnometer method. High-molecular compound: sodium alginate (NaAlg) and low-molecular compounds: pentasodium tripolyphosphate (TPP) and trisodium citrate (CIT) were used as ionic crosslinkers of chitosan. As a reference liquid n-heptane solution was chosen. It was found out that density of modified chitosan membranes is strongly affected by the type of ionic crosslinker and membrane preparation conditions.

Key words: *chitosan membranes, ionic crosslinking, density, pycnometer method, n-heptane.*

1. Introduction

Chitosan (Ch) is one of the most promising polymers for the preparation of membranes for various uses: for instance for pervaporation, ultrafiltration, reverse osmosis, gas separation, purification processes or drug delivery [1].

In all applications mentioned above both mechanical and chemical strength as well as swelling behaviour are important. To improve mechanical and chemical resistance and water permselectivity of chitosan membranes, they are modified by different methods, including crosslinking [1]. In our previous papers we have reported the synthesis of modified Ch membranes obtained by crosslinking of chitosan with sodium alginate (NaAlg) and different low molecular ionic substances: pentasodium tripolyphosphate (TPP), sodium citrate (CIT) and sulphuric acid (SA). We presented data on chemical structure and swelling of the synthesized membranes [2]. Characterization of chitosan hydrogels, similarly as characterization of another hydrogels, should include both chemical as well as physical structure of these materials. The chitosan membranes studied by us are non-porous hydrogels [3] and are composed of solid polymer and water. Each of these phases affects the physical properties of hydrogels, such as density, refractive index, mechanical property, etc.

The present study focuses on density determination of non-crosslinked and ionically crosslinked chitosan membranes. As ionic crosslinkers three different compounds have been used: NaAlg, TPP and CIT. The results of membrane density have been correlated with the membrane structure. An effect of the type of crosslinker and membrane preparation conditions on its density were discussed.

2. Polymer density and methods of its determination

Density (d) is one of the polymer parameters of great importance. Compounds have unique densities that depend on their chemical composition, their physical state and for crystalline solids the nature of the crystalline lattice. For amorphous polymers the density of a sample is influenced by the molecular formula. For a given semicrystalline polymer the density depends on degree of crystallinity. Moreover the degree of crystallinity can be determined by density measurements.

Density is defined as a physical property of matter that expresses a ratio of mass (m) to volume (V) [4]:

$$d = \frac{m}{V} \quad (1)$$

In the literature it can be also found such terms like relative density (d_B^{rel}) and apparent density (d^{app}) [5, 6]. Relative density (Equation 2) is the ratio of the density of a substance (d_A) to the density of a given reference material (d_B) [4]. The usual reference material for solids and liquids is water. The d_B^{rel} of a substance is used by chemists to check the progress of reactions and to characterize the concentration of solutions.

$$d_B^{rel} = \frac{d_A}{d_B} \quad (2)$$

Apparent density is defined as a ratio of mass (m) to total volume (V_t) (the volume limited by the external surface of the specimen including any voids) and is given by Equation 3 [7]. This parameter is commonly used to characterize porous materials.

$$d^{app} = \frac{m}{V_t} \quad (3)$$

Three techniques are widely used to measure densities of polymer samples. These include density gradient column, dilatometry and pycnometry. Moreover, there are several guidelines which researcher can follow to determine density of polymeric materials. Among them different Polish and European Standards can be found [8], such as PN-EN ISO 1183-1:2006; PN-EN ISO 1183-2:2006, PN-EN ISO 1183-3:2003, PN-EN ISO 845:2010, PN-ISO 8962:1996.

For well-known and widely used polymers the methods of density determination are described in detail in Standards relating to a particular compound. Although chitosan has individual Standard PN-89/A-86850:1989 [9] and its supplement PN-A-86850/Az1:1997 [10], there is no information how to determine chitosan's density. Thus, depending on the form of chitosan (powder, membrane, beads), different methods described in the standards enumerated above can be used.

In the present study we propose a modified pycnometer method for density measurement of non-modified and modified chitosan membranes. An attention was also focused on determination of density of reference liquid.

3. Materials and methods

3.1. Materials

Commercially available chitosan (DDA = 77.0% ± 2.3%, M_v = 720 kDa) from crab shells in the powder form was purchased from Sigma Aldrich (Germany). Crosslinking agents: sodium alginate (NaAlg, M_v = 102 kDa), pentasodium tripolyphosphate (TPP) and trisodium citrate (CIT) of analytical grade were purchased from POCh (Poland) or Aldrich (Germany). Other reagents: acetic acid (HAc) and hydrochloric acid (HCl) were both of analytical grade and were purchased from POCh (Poland).

Because both chitosan as well as ionically crosslinked chitosan membranes are hydrophilic, a highly hydrophobic liquid (n-heptane) was chosen for density measurements. n-Heptane (99%) of reagent plus grade was purchased from Aldrich (Germany).

3.2. Membrane preparation and characterization

One-component chitosan membrane (Ch), two-component: chitosan/sodium alginate (Ch/NaAlg), chitosan/pentasodium tripolyphosphate (Ch/TPP) and chitosan/trisodium citrate (Ch/CIT) membranes were prepared according to previously reported methods [2, 3].

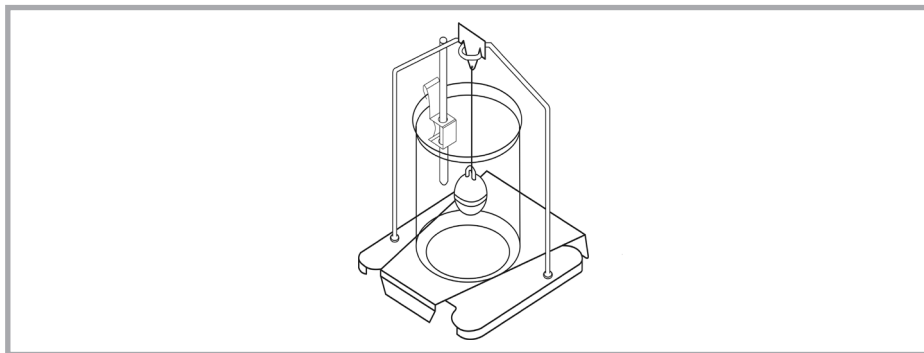

Figure 1. Density measurement set for determination of density of liquids.

All prepared membranes were thoroughly dried under vacuum at 37 °C before polymer density measurements.

3.3. Density measurements

In the first step density of n-heptane used in all experiments was determined by hydrostatic weighing method. Analytical balance AGN200 (AXIS) equipped with density measurement set was applied (**Figure 1**).

To achieve it 40 cm³ of n-heptane was placed in closed thermostatic bath which temperature was set on 25 °C and it was continuously stirred during 30 min. Next, glass float of known volume was weighted in air, immersed in n-heptane and weighted again. Density of liquid (d_l) was determined automatically by balance equipped with HYDRO special function performing arithmetical calculations.

In the second step chitosan membrane density was determined using pycnometer method. Pycnometer of total volume 25 cm³, equipped with thermometer, side capillary and vacuum jacket, was used in all measurements. Because n-heptane volatility has negative effect on measurement accuracy, we have modified the method described in Polish Standard PN-EN ISO 1183-1:2004. All membranes were cut into small pieces and kept in desiccator. Dry and empty pycnometer was weighted on analytical balance (m_p). Pycnometer and n-heptane were thermostated separately at 25 °C for 30 min. Then pycnometer was filled with n-heptane and weighted again (m_{pl}). About 1g of membrane was put into clean and dry pycnometer and weighted (m_{ps}). Pycnometer after being kept for 30 min at 25°C, was filled with n-heptane of 25 °C and weighted again (m_{pls}). Each measurement was at least triplicated.

From the mass and density of n-heptane (d_l) in pycnometer, the pycnometer volume (V_p) was calculated, using **Equation 4**.

$$V_p = \frac{m_{pl} - m_p}{d_l} (4)$$

Volume of the solid matter in pycnometer (V_s), defined as a difference between volume of empty pycnometer and volume of n-heptane above solid matter (V_i'), was obtained from the following relation:

$$V_s = V_p - V_i' \quad (5)$$

where $V_i' = \frac{m_{p1s} - m_{ps}}{d_i}$

Density of the solid was calculated from the final **Equation 6**:

$$d_s = \frac{m_s}{V_s} = \frac{m_{ps} - m_p}{V_p - V_i'} = \frac{(m_{ps} - m_p) \cdot d_i}{m_{p1} - m_p - m_{p1s} + m_{ps}} \quad (6)$$

4. Results and discussion

4.1. Chemical structure of crosslinked membranes

FTIR analysis results presented and described elsewhere [2] indicated the formation of crosslinked membranes with the ionic crosslinks schematically shown in **Scheme 1**.

4.2. Relation between density and membrane structure

According to literature data [5] the temperature dependence of n-heptane density in the temperature range from 0 to 50 °C is linear (coefficient of determination $R^2 = 0.9997$) and it could be described by equation:

$$d [\text{g}\cdot\text{cm}^{-3}] = (-8.501 \pm 0.021) \cdot 10^{-4} \cdot T [^\circ\text{C}] + (0.70064 \pm 0.00005) \quad (7)$$

Experimentally determined density of commercial-grade n-heptane at 25 °C was equal to 0.67873 g·cm⁻³ and density of n-heptane obtained from the relationship presented above was equal to 0.679388 ± 0.000073 g·cm⁻³. Only 0.1% difference between experimental and literature values was found. We suppose, that it might result from the presence of 1% of other compounds in n-heptane commercial solution [11]. In further calculations the experimentally obtained density of n-heptane was used.

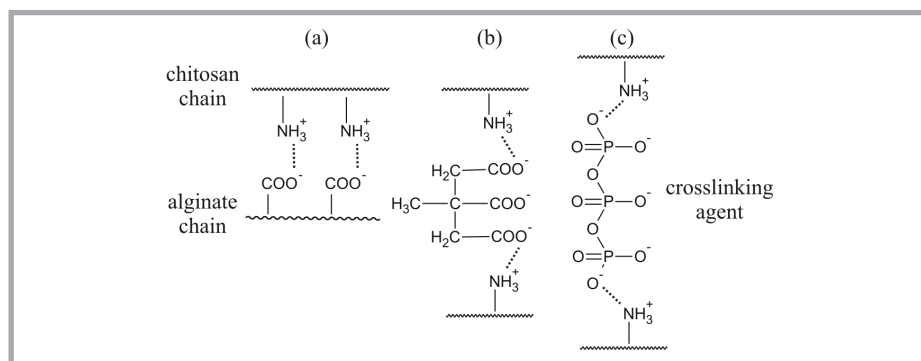

Scheme 1. Structure of ionic crosslinks between NH_3^+ groups of Ch and (a) groups of Alg, (b) TPP and (c) CIT ions.

Table 1. Densities of non-modified and modified chitosan membranes.

Membrane	Density, g·cm ⁻³
Ch	1.478
Ch/NaAlg	1.515
Ch/CIT	1.562
Ch/TPP (pH _{TPP} = 5.5)	1.742
Ch/TPP (pH _{TPP} = 9.0)	1.448

In **Table 1** densities of non-modified (non-crosslinked) and modified (ionically crosslinked) chitosan membranes are shown. The presented data indicate, that density of all crosslinked chitosan membranes, besides Ch/TPP (pH_{TPP} = 9.0) membrane, is higher than density of Ch membrane. Values of d_s for Ch and Ch/TPP (pH TPP = 9.0) are similar.

Density of pure chitosan membrane is in good agreement with data presented in literature, i.e. 1.438 g·cm⁻³ [12], 1.455 g·cm⁻³ [6], 1.45 g·cm⁻³ [13] and 1.4257 g·cm⁻³ [14]. In our opinion both chitosan origin as well as membrane preparation procedure affect the physical structure of chitosan membrane and thus its density.

Density of two-component Ch/NaAlg membrane is only slightly higher (2.4%) than d_s of Ch. This membrane consists of 75 wt.% Ch and 25 wt.% NaAlg. Taking into account density of Ch (1.478 g·cm⁻³) and NaAlg (0.8755 g·cm⁻³ [15]) and the simple relation between density of a polymer sample and relative densities and masses of its components [16], a lower value of d_s might be expected. The observed increase in d_s indicates that the structure of Ch/NaAlg becomes more compact. It can be concluded that ionic crosslinks between protonated amino groups of chitosan and carboxylate groups of alginate (Scheme 1a) and other physical interactions, like hydrogen bonds, lead to more dense, better packed structure with higher bulk density.

Analysis of results for chitosan membrane crosslinked with TPP at different pH. **Table 1** shows that the membrane crosslinked in acidic pH has higher density than Ch, but membrane crosslinked in alkaline pH has similar density to Ch. We have reported earlier [3] that the conditions of the crosslinking process strongly affect both the molecular as well as the supermolecular structure of chitosan membrane. The lower TPP solution pH and longer crosslinking time lead to Ch/TPP membrane of higher crosslinking density. Both Ch/TPP membranes studied in this paper were synthesized by diffusion of crosslinking agent (TPP) from solution of pH = 5.5 and pH = 9.0, respectively, into the earlier prepared chitosan membrane. In both cases the time (time of crosslinking process) of TPP diffusion was analogous. Thus, we can conclude that the obtained membranes differ in the content of ionic bonds between protonated amino groups of chitosan and TPP ions (**Scheme 1.b**). Differences in Ch/TPP membrane densities result most probably from differences in crosslinking density. Next, the difference in crosslinking density results from unequal ionization of TPP in solution of different pH [17].

Figure 2 shows the results of calculations of degree of ionization of chitosan and the charge number of tripolyphosphate ions and citrate ions for different pH of solution. In

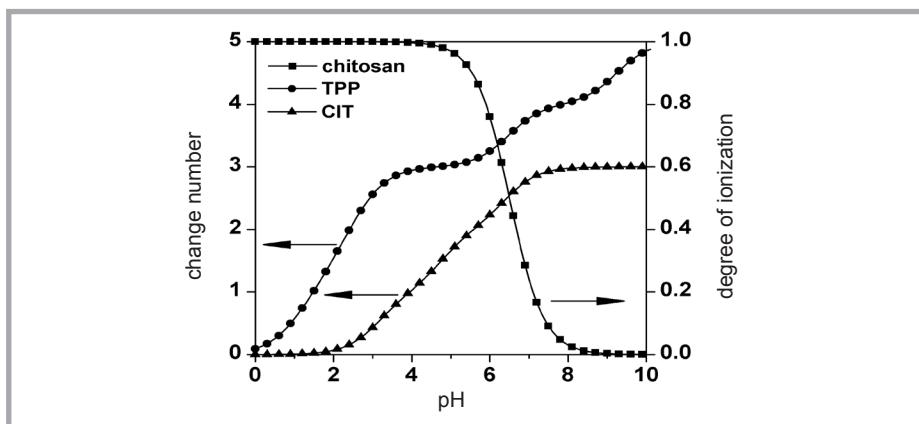

Figure 2. Charge number of tripolyphosphate and citrate ions and degree of ionization of chitosan as a function of pH.

calculations the values of $pK_a = 6.5$ [18], $pK_{a1} = 1$, $pK_{a2} = 2$, $pK_{a3} = 2.79$, $pK_{a4} = 6.47$, $pK_{a5} = 9.24$ [19] and $pK_{a1} = 3.138$, $pK_{a2} = 4.76$, $pK_{a3} = 6.401$ [20] for chitosan, TPP and CIT ions, respectively, were used.

With increasing pH degree of ionization of chitosan decreases (strongly near $pK_a = 6.5$ value), but in contrast charge number of TPP increases (**Figure 2**).

In $pH = 5.5$ both substrates are highly ionized, thus product of its reaction exhibits high crosslinking density and high density as well. In $pH = 9.0$ crosslinking of chitosan membrane, that is only slightly ionized, results in Ch/TPP membrane of lower crosslinking density and thus lower density. Because the crosslinking of chitosan in basic solution is so minimal then densities of Ch/TPP ($pH_{TPP} = 9.0$) and Ch membranes are almost equal.

We have found that the swelling behaviour of chitosan membrane strongly depends on pH and degree of its swelling increases with decreasing of pH [17]. Thus, it can be concluded, that higher crosslinking degree of Ch/TPP membrane prepared in acidic conditions is also a result of high swelling of Ch that facilitates diffusion of crosslinker ions to the membrane interior.

There are also observed some differences in density of chitosan membranes modified at the same experimental conditions (pH, crosslinking time, temperature) but using different low – molecular ionic compounds, i.e. pentasodium tripolyphosphate and trisodium citrate (**Table 1**). Ch/CIT ($pH_{CIT} = 5.5$) is characterized by density higher than Ch, but lower than Ch/TPP ($pH_{TPP} = 5.5$). To answer what is a reason of the observed differences in d_s we have analyzed the degree of ionization of Ch, TPP and CIT in solution of $pH = 5.5$. When we prepare Ch/TPP and Ch/CIT membranes, then in both cases the number of protonated amino groups and degree of swelling of chitosan are identical. At $pH = 5.5$ charge number of CIT is equal to 1.956 (mainly divalent ions are present in the solution), and of TPP 3.095 (**Figure 2**). Thus, it could be assumed that observed differences in d_s are result of varia-

tion in crosslinker charge number and the number and nature of ionic groups in crosslinker molecule.

In the discussion presented above we have not analysed the effect of polymer crystallinity on membranes density. Sometimes degree of crystallinity can have a noticeable effect on the density of polymer. In semicrystalline polymers the measured density of a sample provides a simple way to estimate the degree of crystallinity according to the following relation [21]:

$$\text{weight \% crystallinity} = \frac{d_c \cdot (d_s - d_a)}{d_s \cdot (d_c - d_a)} \quad (8)$$

where d_s , d_c and d_a are the sample density, the density of 100% crystalline polymer and the density of the amorphous polymer, respectively.

As results from our X-ray diffraction studies, both chitosan as well as modified chitosan are semicrystalline polymers. Crystallinity of chitosan decreased after its crosslinking, but the effect of ionic crosslinking on membrane crystallinity was rather small. Small decrease of polymer crystallinity can cause only very small decrease of bulk membrane density.

4. Conclusions

Density of chitosan membranes is strongly affected by the type of ionic crosslinker and membrane preparation conditions. In the case of chitosan membranes crosslinked with sodium alginate, pentasodium tripolyphosphate and trisodium citrate, density increases in series: Ch/TPP ($\text{pH}_{\text{TPP}} = 9.0$) \approx Ch < Ch/NaAlg < Ch/CIT < Ch/TPP ($\text{pH}_{\text{TPP}} = 5.5$). Density of ionically crosslinked membranes is strongly affected by degree of ionization of polymer (chitosan and alginate) and charge number of low-molecular ionic crosslinker (TPP, CIT).

5. References

1. Uragami T; (2011) Separation Membranes from Chitin and Chitosan Derivatives. In: Kim S-K (ed), Chitin, Chitosan, Oligosaccharides and Their Derivatives. CRC Press, Boca Raton, chapter 34, 481-506.
2. Pieróg M, Gierszewska-Drużyńska M, Ostrowska-Czubenko J; (2009) Effect of ionic crosslinking agents on swelling behaviour of chitosan hydrogel membranes. In: Jaworska MM (ed), Progress on Chemistry and Application of Chitin and its Derivatives. Polish Chitin Society, Łódź, 75-82.
3. Gierszewska-Drużyńska M, Ostrowska-Czubenko J; (2011) Influence of crosslinking process conditions on molecular and supermolecular structure of chitosan hydrogel membrane. In: Jaworska MM (ed), Progress on Chemistry and Application of Chitin and its Derivatives. Polish Chitin Society, Łódź, 15-22.
4. Stasicka Z, Achmatowicz O (eds); (2005) Kompendium terminologii chemicznej. ZamKor, Kraków.
5. Timmermans J; (1950) Physico-chemical constants of pure organic compounds. Elsevier Publishing Company, Brussels.

6. Matsuyama H, Kitamura Y, Naramura Y, (1999) Diffusive permeability of ionic solutes in charged chitosan membrane. *J Appl Polym Sci* 72, 397-404.
7. Broniewski T, Kapko J, Płaczek W, Thomalla J; (2000) Metody badań i ocena właściwości tworzyw sztucznych. WNT, Warszawa.
8. Official website of Polish Committee for Standardization (www.pkn.pl).
9. PN-89/A-86850:1989: Chitozan – Surowce i przetwory z ryb i innych zwierząt wodnych.
10. PN-A-86850/Az1:1997: Chitozan - Surowce i przetwory z ryb i innych zwierząt wodnych.
11. Certificate of analysis of n-heptane solution by Aldrich ([www.sigmaaldrich.com /Graphics/ CO-fAInfo/fluka/pdf/PDF371413.pdf](http://www.sigmaaldrich.com/Graphics/CO-fAInfo/fluka/pdf/PDF371413.pdf)).
12. Uragami T, Matsuda T, Okuno H, Miyata T; (1994) Structure of chemically modified chitosan membranes and their characteristics of permeation and separation of aqueous ethanol solutions. *J Membr Sci* 88, 243-251.
13. Uragami T, Kato S, Miyata T; (1997) Structure of N-alkyl chitosan membranes on water-permselectivity for aqueous ethanol solutions. *J Membr Sci* 124, 203-211.
14. Tsai H-S, Wang Y-Z; (2008) Properties of hydrophilic chitosan network membranes by introducing binary crosslink agents. *Polym Bull* 60, 103-113.
15. Lee KY, Bouhadir KH, Mooney DJ; (2000) Degradation behavior of covalently cross-linked poly(aldehyde guluronate) hydrogels. *Macromolecules* 33, 97-101.
16. Calhoun A, Peacock AJ; (2006) *Polymer Chemistry: Properties and Applications*. Carl Hanser Verlag, Munich.
17. Ostrowska-Czubenko J, Pieróg M, Gierszewska-Drużyńska M; (2011) Equilibrium swelling behavior of crosslinked chitosan hydrogels. *Pol J Appl Chem* LV(2), 49-56.
18. Wang QZ, Chen XG, Liu N, Wang SX, Liu CS, Meng XH, Liu CG; (2006) Protonation constants of chitosan with different molecular weight and degree of deacetylation. *Carbohydr Polym* 65, 194-201.
19. Shu XZ, Zhu KJ; (2002) The influence of multivalent phosphate structure on the properties of ionically cross-linked chitosan films for controlled drug release. *Eur J Pharm Biopharm* 54, 235-243.
20. Dawson RMC (ed); (1969) *Data for biochemical research*. Clarendon Press, Oxford.
21. Przygocki W, Włochowicz A; (2006) *Uporządkowanie makrocząsteczek w polimerach i włóknach*. WNT, Warszawa.

